

Valvola OVERCENTER compensata in pressione doppio effetto  
 Double effect pressure compensated COUNTERBALANCE valve

mod. OVC-DE-CC

Corpo in alluminio  
 Aluminium body

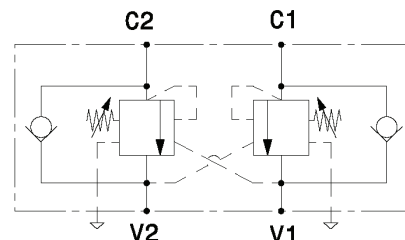
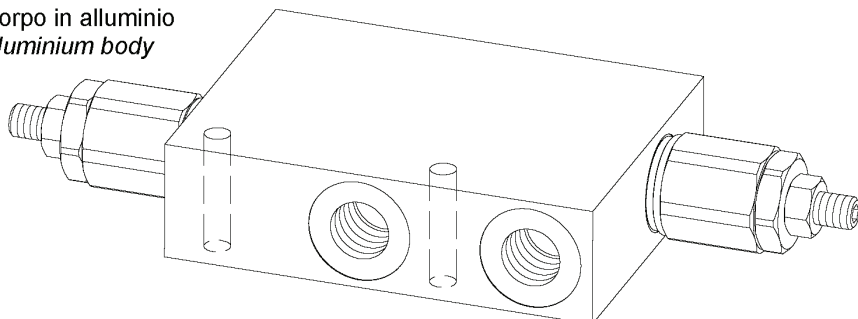

Pressione massima Max pressure	350 bar 5000 psi
Rapporto di pilotaggio standard Standard pilot ratio	4,25:1
Rapporto di pilotaggio a richiesta Pilot ratio upon request	3:1 8:1 10:1

Dati e tarature ottenuti usando olio con viscosità 30 cSt a 50°C Performances and calibrations are carried out by using hydraulic oil with 30 cSt viscosity at 50°C	
Viscosità consigliate Recommended viscosity	10 ÷ 420 cSt
Temperature di lavoro Working temperature	-20 ÷ +90 °C
Filtrazione assoluta Absolute filtration	25 µ

Modello Type	V1, C1 V2, C2	Portata max Max. flow
OVC-DE-CC-38	3/8" GAS	40 l/min 10.5 gpm
OVC-DE-CC-12	1/2" GAS	60 l/min 16 gpm

Taratura Setting	La valvola deve essere tarata almeno 1.3 volte la massima pressione indotta dal carico The valve must be set at least 1.3 times maximum load induced pressure		
Codice Code	Taratura standard Standard setting (Q=5 l/min)	Campo di taratura Adj. Pressure range	Colore molla Spring color
01	100 bar 1450 psi	20÷200 bar 290÷2900 psi	Bianco White
02	280 bar 4000 psi	50÷350 bar 725÷5000 psi	Nero Black

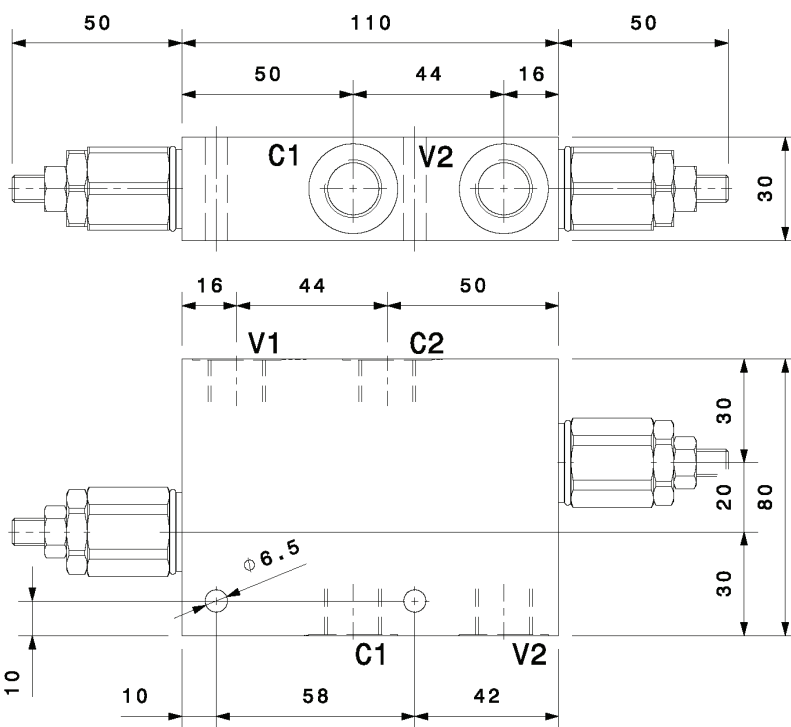

Regolazioni - Adjustments

-	<b>C</b>	<b>D</b>
Vite esterna esagono incassato Leakproof hex socket screw	Piombatura Sealing cap	Cappello Cap

Sigla di ordinazione / Ordering code

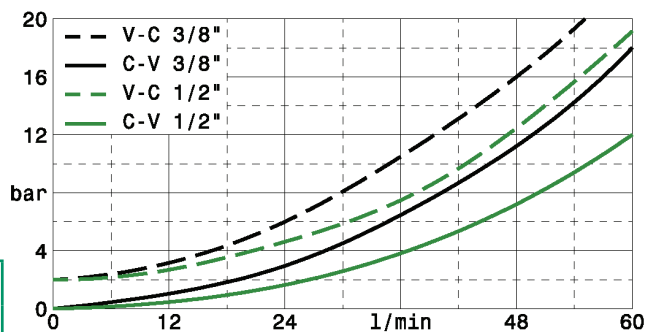
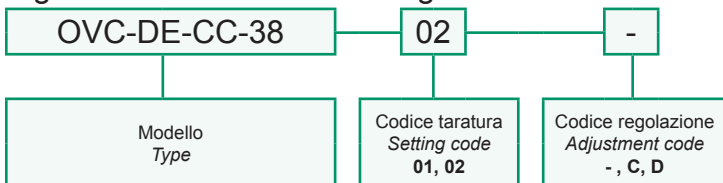

I dati non sono impegnativi, CBF si riserva di apportare modifiche senza preavviso.  
 The specifications are not binding, CBF reserves the right to introduce modifications without notice.